



Accuracy

Improved version of the popular EE08 high accuracy air temperature and relative humidity probe from E + E Elektronik



Accuracy Over Measurement Range

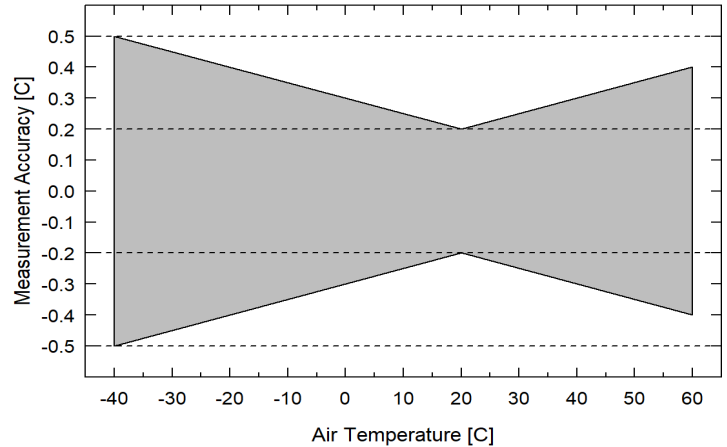

Product Specifications

EE08-SS	
Input Voltage	7 to 30 V DC
Current Draw	Less than 1.3 mA
Start-up Time	2 s
Housing	Polycarbonate, IP65
Filter	Stainless steel wire mesh, 30 micron pore size
Connector	M12, IP67
Dimensions	83 mm length, 12 mm diameter
Mass with 5 m Cable	270 g
Operating Environment	-40 to 80 C; 0 to 100 % relative humidity
Cable	M12 connector (IP67 rating) to interface to sensor housing, 5 m of four conductor, shielded, twisted-pair wire (10 m and 20 m cables also available), white TPR jacket (high water resistance, high UV stability, flexibility in cold conditions), pigtail lead wires
Warranty	1 year against defects in materials and workmanship

Temperature Measurement		Relative Humidity Measurement	
Sensor	PT1000 (Class A)	Sensor	Capacitance Chip
Measurement Range	-40 to 60 C	Measurement Range	0 to 100 %
Output Signal Range	0 to 2.5 V DC	Output Signal Range	0 to 2.5 V DC
Slope	0.04 C per mV	Slope	0.04 % per mV
Intercept	-40 C	Intercept	0.00 %
Accuracy at 20 C	± 0.2 C	Accuracy at 20 C	± 2 % from 0 to 90 %; ± 3 % from 90 to 100 %
Long-term Stability	Less than 0.1 C per year	Temperature Response	Less than -0.05 % per C
Time Constant	Less than 30 s	Long-term Stability	Less than 1 % per year
Accuracy Over Measurement Range	See graph above	Time Constant	Less than 30 s

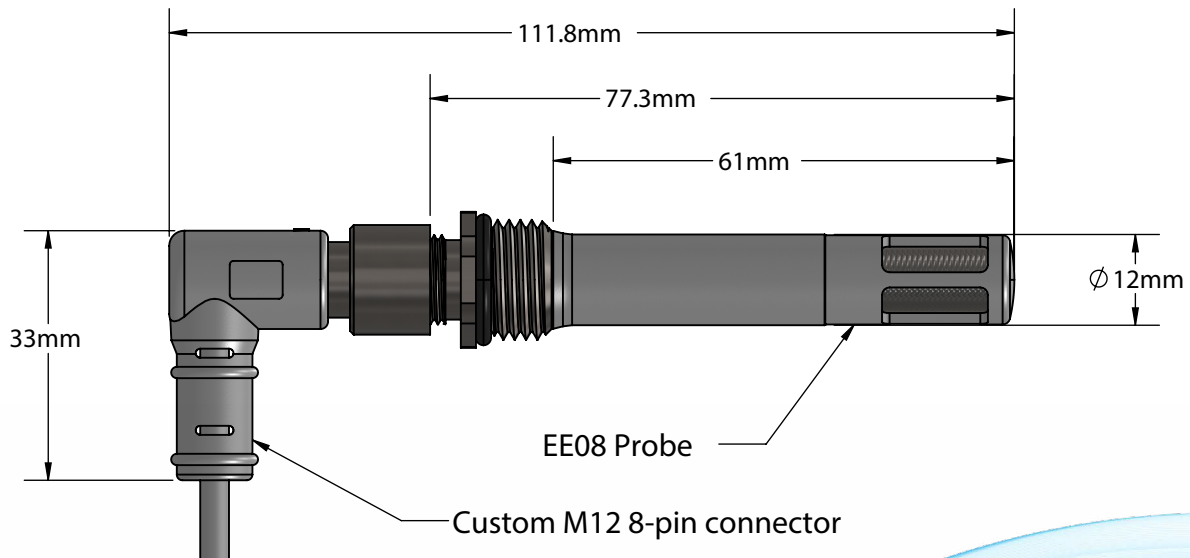

Features

TYPICAL APPLICATIONS

- Meteorology and Weather stations
- Hatcheries and incubators
- Climatic chambers and green houses
- Storage rooms
- Artificial snow machines
- Battery operated devices

AERODYNAMIC SHAPE

The Apogee EE08-SS is a customized version of the EE08 probe made by Austrian manufacturer E + E Elektronik. After years of evaluation, the EE08-SS has emerged as our sensor of choice over more expensive probes for accuracy, stability, and durability. The Apogee EE08-SS features an improved right angle, IP67 rated, stainless-steel M12 connector; heat-reflective white cabling; and a more durable, metal-grid dust filter. These features added by Apogee only slightly increase the price over the base model from E + E, but greatly improve the performance and reduce the maintenance of the probe, especially when used with a fan-aspirated radiation shield like the Apogee TS-100.

