

## Spectral Response

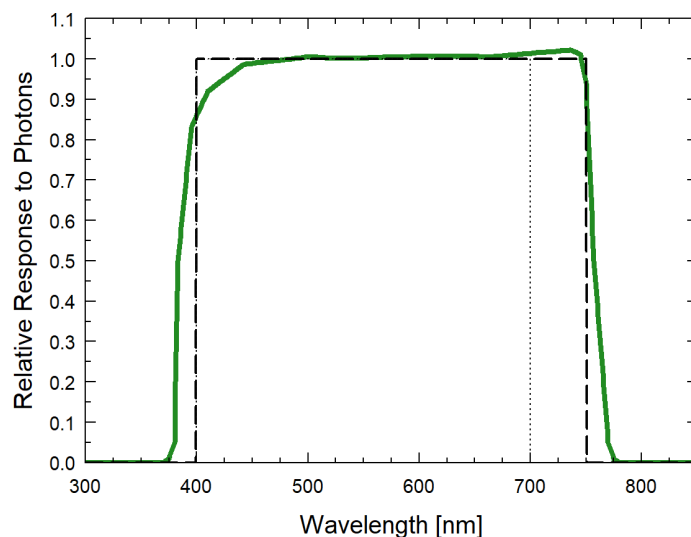

Spectral response of the ePAR sensor (green) compared to the “ePAR” target response (dashed) and the traditional PAR response (dotted).

## Product Specifications

MQ-610	
Calibration Uncertainty	± 5 %
Measurement Range	0 to 4000 $\mu\text{mol m}^{-2} \text{s}^{-1}$
Measurement Repeatability	Less than 0.5 %
Long-term Drift (Non-stability)	Less than 2 % per year
Non-linearity	Less than 1 % (up to 4000 $\mu\text{mol m}^{-2} \text{s}^{-1}$ )
Response Time	Less than 1 ms
Field of View	180°
Spectral Range	383 to 757 nm $\pm$ 5 nm (wavelengths where response is greater than 50 % of maximum)
Directional (Cosine) Response	$\pm$ 2 % at 45° zenith angle, $\pm$ 5 % at 75° zenith angle
Azimuth Error	Less than 0.5 %
Tilt Error	Less than 0.5 %
Temperature Response	-0.11 $\pm$ 0.04 % per C
Uncertainty in Daily Total	Less than 5 %
Detector	Blue-enhanced silicon photodiode
Housing	Anodized aluminum body with acrylic diffuser
IP Rating	IP68
Operating Environment	0 to 50 C; less than 90 % non-condensing relative humidity up to 30 C; less than 70 % non-condensing relative humidity from 30 to 50 C; separate sensors can be submerged in water up to 30 m
Cable	2 m of shielded, twisted-pair wire; additional cable available; TPR jacket
Warranty	4 years against defects in materials and workmanship

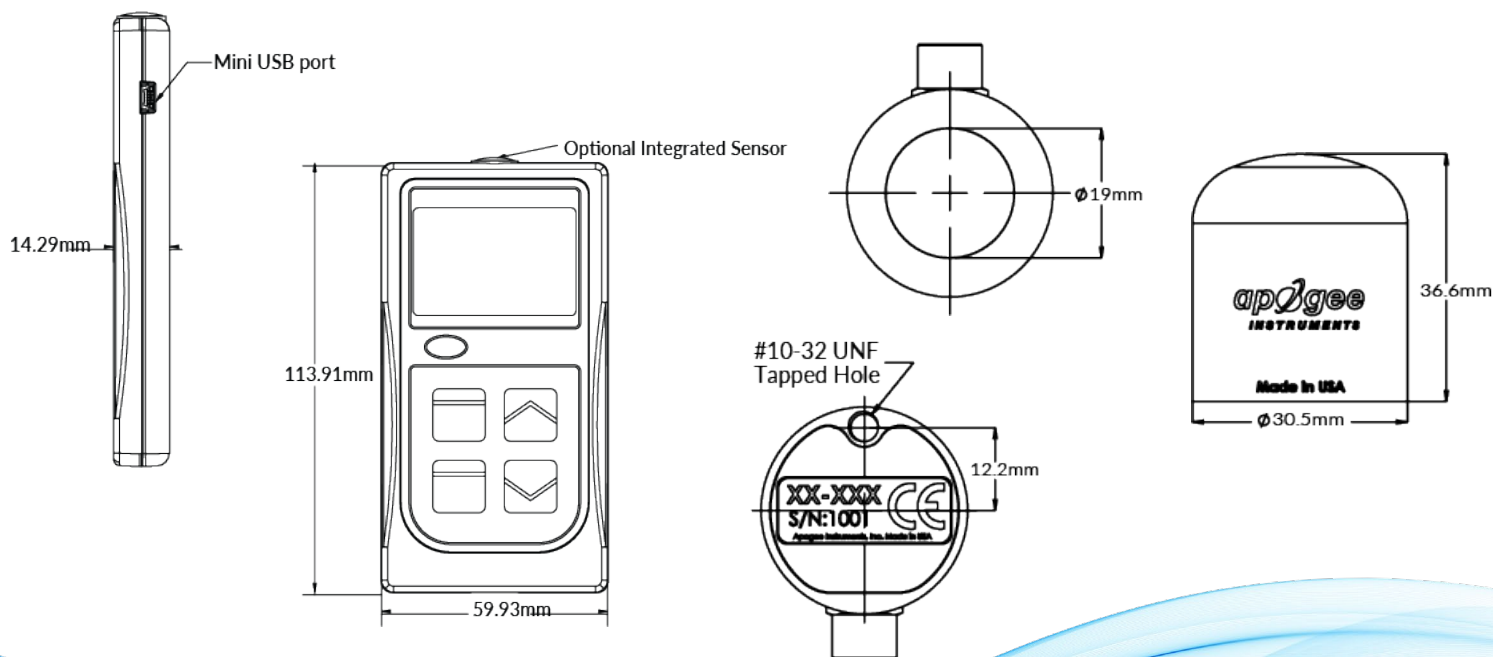

## Features

### OVERVIEW

The new Apogee ePAR (extended PAR) sensor was created to measure the wider 400-750 nm radiation range that cutting-edge research is showing to be photosynthetically active, beyond the traditional 400-700 nm range defined by McCree. Most of this transformative work to refine and define the ePAR range is being conducted by Dr. Shuyang Zhen and Dr. Bruce Bugbee at Utah State University.

### TYPICAL APPLICATIONS

- Total ePAR intensity measurements over plant canopies in all growing environments
- Monitor and adjust grow lights
- Research plant morphogenic activity
- Photobiology studies

### UNIQUE DESIGN

Measure photosynthetic photon flux density (PPFD) with a research grade, extended spectral response sensor. Offers a self-cleaning, cosine-corrected head that is fully-potted for a waterproof design.

### ACCURATE, STABLE MEASUREMENTS

Cosine-corrected with directional errors less than  $\pm 5\%$  at a solar zenith angle of  $75^\circ$ . Long-term non-stability less than 2% per year.



### CALIBRATION TRACEABILITY

Apogee Instruments SQ-600 series ePAR sensors are calibrated through side-by-side comparison to the mean of four transfer standard sensors under a reference lamp. The transfer standard sensors are recalibrated with a quartz halogen lamp traceable to the National Institute of Standards and Technology (NIST).