

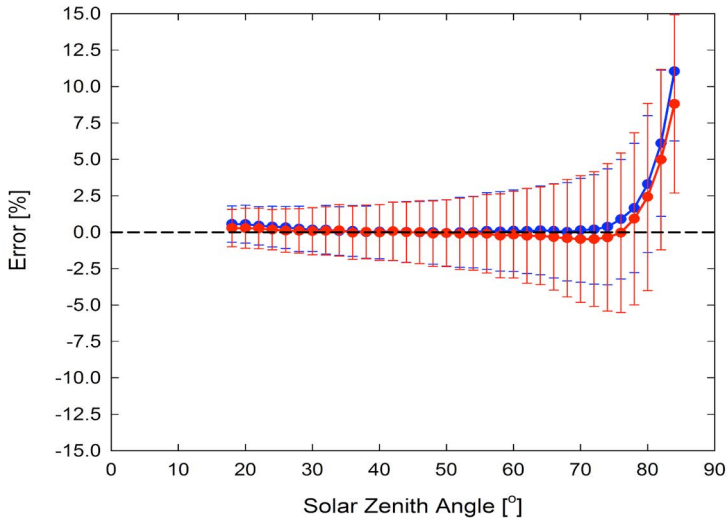

Response Graphs

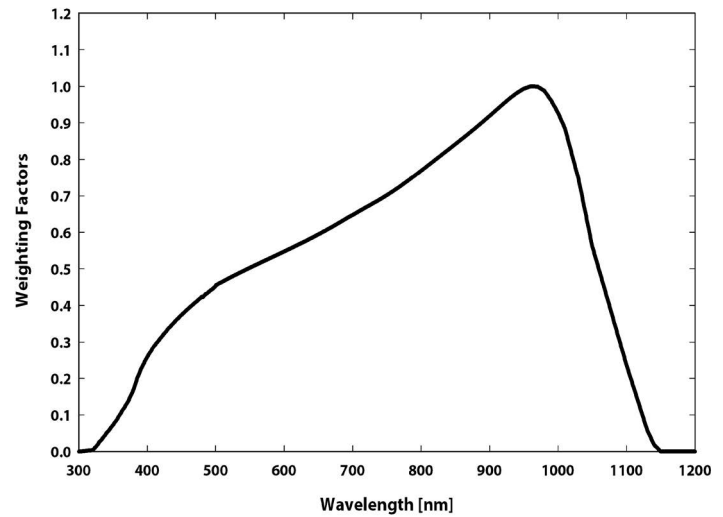

Mean **cosine response** of eleven Apogee silicon-cell pyranometers (error bars represent two standard deviations above and below mean). The blue symbols are AM measurements; the red symbols are PM measurements.



Spectral response estimate of Apogee silicon-cell pyranometers.

Product Specifications

	MP-100	MP-200
Calibration Uncertainty at 1000 W m ⁻²		Less than 3 %
Measurement Repeatability		Less than 1 %
Long-term Drift		Less than 2 % per year
Non-linearity		Less than 1 % up to 2000 W m ⁻²
Response Time		Less than 1 ms
Field of View		180°
Spectral Range		360 to 1120 nm
Directional (Cosine) Response		± 5 % at 75° zenith angle
Temperature Response		-0.04 ± 0.04 % per C
Operating Environment	0 to 50 C; less than 90 % non-condensing relative humidity up to 30 C; less than 70 % non-condensing relative humidity from 30 to 50 C; separate sensors can be submerged in water up to depths of 30 m	
Sensor Dimensions	Integrated with Meter	24 mm diameter, 33 mm height
Meter Dimensions	126 cm length, 70 mm width, 24 mm height	
Mass	150 g	180 g
Cable	2 m of shielded, twisted-pair wire; additional cable available; TPR jacket (high water resistance, high UV stability, flexibility in cold conditions)	
Warranty	4 years against defects in materials and workmanship	

Calibration Traceability

Apogee SP series pyranometers are calibrated through side-by-side comparison to the mean of four transfer standard sensors under a reference lamp. The reference sensors are recalibrated under sunlight in Logan, UT traceable to the World Radiometric Reference (WRR) in Davos, Switzerland.

Dimensions

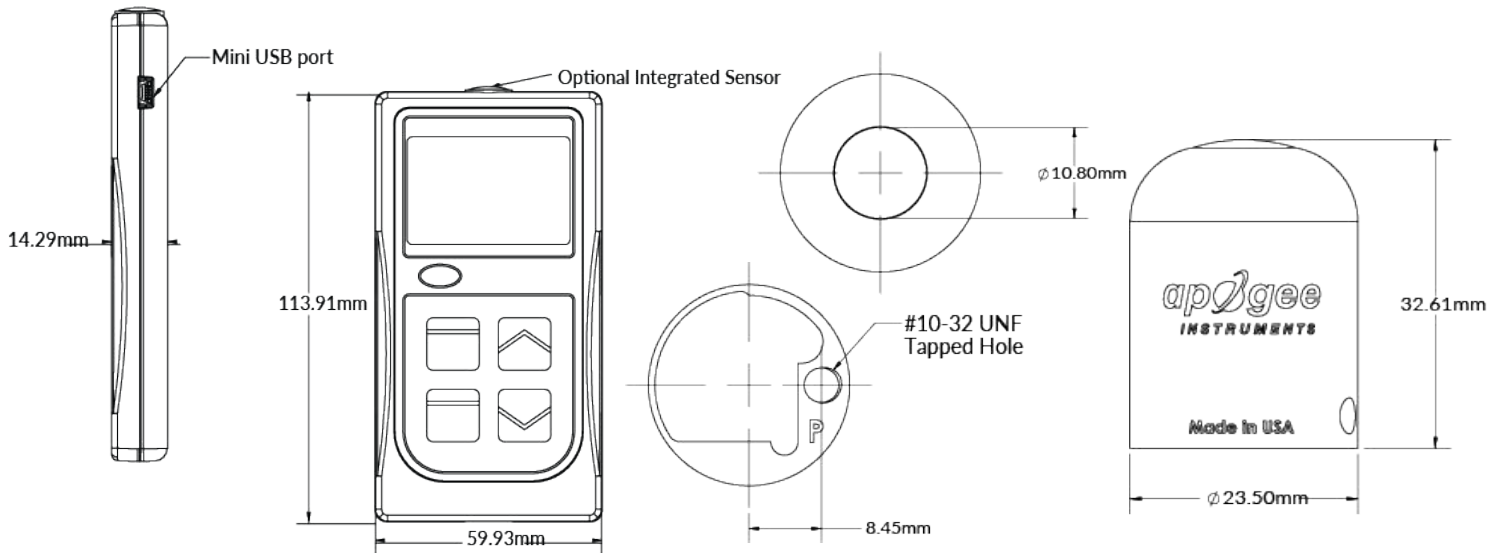

Features

TYPICAL APPLICATIONS

- Solar panel arrays
- Agricultural, ecological, and hydrological weather networks

STABLE MEASUREMENTS

Long-term non-stability determined from multiple replicate pyranometers in accelerated aging tests and field conditions is less than 2 % per year.

UNIQUE DESIGN

A patented dome-shaped sensor head keeps the sensor clean and minimizes errors by shedding water. Sensors are housed in a rugged anodized aluminum body and electronics are fully-potted.



MP-100